



The Effect of Roof Openings on Passive Cooling in Mosque Interiors

Hatice Sena Azkur¹, Murat Oral²

¹ Graduate Education Institute, Konya Technical University, Department of Architecture, senaazkur@gmail.com, ORCID: 0000-0001-7448-9281 (corresponding author)

² Faculty of Architecture and Design, Konya Technical University, Department of Interior Architecture, moral@ktun.edu.tr, ORCID: 0000-0003-4848-5417

This publication is a part of an ongoing doctoral dissertation of the first author under the supervision of the second author

ABSTRACT

It is known that the energy needs of a naturally ventilated building consume 40% less energy than a mechanically ventilated building. Especially in summer months, the energy needs of mosques increase greatly due to cooling loads. The aim of the study is to provide passive cooling with the stack effect by taking advantage of the large floor height of mosques compared to other buildings and to evaluate the effect of the number of roof openings on passive cooling. Within the scope of the study, a prototype mosque was designed in line with general practices and regulations in Türkiye. Two different opening alternatives were created. In the first alternative, air outlets are created as a single large opening. In the second alternative, the number of openings was increased to four, but the air outlet size remained the same in total. The two prepared alternatives were transferred to ANSYS Fluent software. In this way, the passive cooling of the building was visualized through simulation. The temperature and velocity contour graphs were created as a result of the analysis. According to the results, the alternative in which more than one roof opening was designed, provided better passive cooling than the alternative with a single opening.

Keywords: natural ventilation, mosque architecture, passive cooling, stack ventilation, wind-driven ventilation

1. INTRODUCTION

The use of air conditioning for cooling purposes in the summer months is rapidly becoming widespread. Accordingly, energy consumption due to air conditioning use is also increasing in parallel, and consuming more energy results in more carbon emissions. In this context, natural ventilation appears as a natural and environmentally friendly alternative to the use of air conditioning. Natural ventilation provides effective passive cooling when applied with the correct design.

Mosque buildings emerged due to the need to worship collectively, which is a part of the Islamic religion. Mosques consist of a minaret and places of worship oriented towards the qibla. Since there are volumes that hold large groups together, the floor height is kept high so that the increased square meters do not give the feeling of a two-dimensional space. In these buildings, where the floor height is 4 - 5 times higher than the human scale, it is possible to provide effective ventilation with the stack effect by arranging roof openings. In the past, since it was not possible to control skylights remotely through automation, such roof openings were not designed in mosques. However, today, these openings can easily be controlled remotely and closed in rainy weather, or can even be automatically opened when necessary with temperature sensors. Examples of this type of window are the openings designed by Renzo Piano on the roof of the California Academy of Sciences. Today, despite the availability of technological opportunities, the most preferred method in new mosques is to design windows at ground level or to condition the environment completely mechanically by designing all windows as fixed. The operable window design on the roof is not used and the natural ventilation and cooling potential in mosques is



ignored. Budaiwi et al.'s (2013) study revealed that 73% of the total energy consumed in mosque buildings was energy consumed for cooling purposes in the summer months. This shows that carbon emissions can be significantly reduced by minimizing energy consumption in mosques during the summer months with natural ventilation.

The main studies on natural ventilation in mosques in the last twenty years are listed below. İmam (2003) conducted a study on the use of mosque minarets, which currently only serve a visual function, as windcatchers and revealed that they could have positive effects on the ventilation of the interior of the building. Al-Homoud et al. (2009) examined three mosques in Saudi Arabia in terms of energy consumption. This study has shown that there is serious energy consumption, especially in the summer months, because of the air conditioning devices used for cooling. In Asfour's (2009) study, the thermal comfort evaluations of two types of mosques, Ottoman style, and Arabic style, were examined comparatively. According to the results of the research, different types of mosque styles performed better in different seasons. Maarof's (2014) study evaluated the effect of hipped roofs and domes on thermal comfort in naturally ventilated mosques. While the dome type gave more positive results in large-capacity mosques, the hipped roof type showed better performance in small-capacity mosques. Al Sudany (2015) used the minaret of a mosque in Iraq as a windcatcher and evaluated the contribution of humidification to cooling by adding a water spray system with CFD analysis. Mustaha and Helmy's study (2017) evaluated the effects of different forms of mosque structures on thermal comfort in hot and humid climate conditions. A newly built mosque and a historical mosque in Malaysia were examined in an experimental study by Nordin and Misni (2017). Temperature fluctuations occurred throughout the day in the new mosque, while in the historical mosque, temperatures increased steadily in the afternoon. Ray et al. (2017) evaluated the natural ventilation design with CFD analysis in a mosque design project. Nordin and Misni (2018) evaluated the thermal performance of three mosques in Malaysia by making measurements by devices in an experimental study. Alhasan and Yuning (2019) researched mosques in China. They measured the effects of mosque courtyards on ventilation and thermal performance according to their orientation using CFD analysis. Atmaca and Gedik (2019) comparatively revealed the energy consumption and thermal comfort performances of two mosques in Istanbul. Othman et al. (2019) examined how natural ventilation in a domed mosque in Malaysia is affected by the window openings. It was observed that larger openings in the prevailing wind direction and smaller openings in the leeward areas were more efficient. The natural ventilation features of an existing mosque in Indonesia were examined in Rahim and Marassabessy's (2019) study. Sanusi et al. (2019) evaluated the mosques built during the British colonial period in Malaysia with the help of experimental studies and simulations. Yusoff and Jaafar (2019) conducted an experimental study by measuring the thermal performance of a historical mosque in Malaysia with the help of devices. Muhammad et al. (2020) modeled a historical mosque in Egypt and examined it with a wind tunnel test. Yuksel et al. (2020) measured CO₂ and temperature values with the help of devices in a mosque in Türkiye and evaluated indoor comfort. Azmi et al. (2021) collected the factors affecting energy consumption in mosques in a review article. Diler et al. (2021) evaluated the thermal performance of a historical mosque in Manisa with device measurements and simulations. Raslı et al. (2021) examined the thermal comfort performance of twenty-one mosques in Malaysia. It was determined that the factors that most affect thermal comfort are window-wall ratios and window type.

The literature review covers various topics such as the use of minarets as wind catchers, the evaluation of different mosque styles, the investigation of the effect of architectural elements on thermal comfort, and the evaluation of the effects of courtyard orientation. The diversity of these studies highlights the versatile nature of natural ventilation solutions for mosques. However, if it is compared with other building types such as offices or residences, studies on the energy and thermal performance of mosques are still few. Some of the literature is on evaluating the thermal performance of existing mosque buildings. Computational Fluid Dynamics (CFD) based studies have started to be carried out in recent



years, and new simulation studies in this field will contribute to the literature. Especially in the design phase, using CFD offers the opportunity to increase the sustainability performance of buildings at this stage.

This study aims to emphasize that mosque buildings, which differ from other building types in their floor height, can be passively cooled with the help of roof openings. Two different opening alternatives were created. In the first alternative, air outlets are created as a single large opening. In the second alternative, the number of openings was increased to four so that the air outlet opening size remained the same in total. Thus, two different opening types were compared through simulations which were obtained by CFD analysis. By identifying the more efficient alternative, data that architects can use in the early design phase has been obtained.

2. MATERIALS AND METHODS

Passive cooling uses temperature differences and renewable energy sources such as wind to provide the cooling and ventilation needs of a building. This also eliminates or reduces the need to use mechanical cooling. Implementing passive cooling means reducing the differences between outside and inside temperatures, improving indoor air quality, and making the building a more comfortable living environment. It reduces environmental impacts such as energy use levels and greenhouse gas emissions. As part of the movement towards sustainable architecture, interest in passive design for heating or cooling has increased recently. Well-designed building envelopes maximize the cooling action of wind and keep out the sun in summer.

2.1. Passive Cooling Strategies

Many passive cooling strategies can be recommended for use in different climates. Proper window placement and daylight design, appropriate glass selection for windows or skylights, use of light or reflective colored materials for the building envelope and roof, appropriate landscape design, as well as careful positioning and smart orientation decisions are some of these strategies (Taleb, 2014).

Operable Windows and Building Voids

Today, many buildings are designed with only fixed windows and mechanical ventilation systems, ignoring the natural ventilation needs of the users. Ventilation rates of windows with different opening styles are different. The effects of different window configurations to be used in building design on ventilation also vary. Buildings with operable windows increase user satisfaction by allowing users to control their physical environment. High windows with openings at the top and bottom are efficient in providing convection and taking in winds from the outdoors. Clerestory windows or windows close to the roof increase convection and provide a great effect on the evacuation of hot air (Jaffe et al., 2020).

Single-sided Ventilation and Cross Ventilation

While single-sided ventilation refers to ventilation with the help of an opening on a single surface of the building, cross-ventilation refers to ventilation that occurs by directing the air taken in within the building by using openings created in different directions from different surfaces of the building (Figure 1). Positive pressure is created on the facade in the direction of the prevailing wind and the wind is taken into the building. The air moves towards the negative pressure region (leeward area) and exits the building from this section. If the structure cannot be positioned in the direction of the prevailing wind, the wind can be directed with appropriate afforestation and planting.

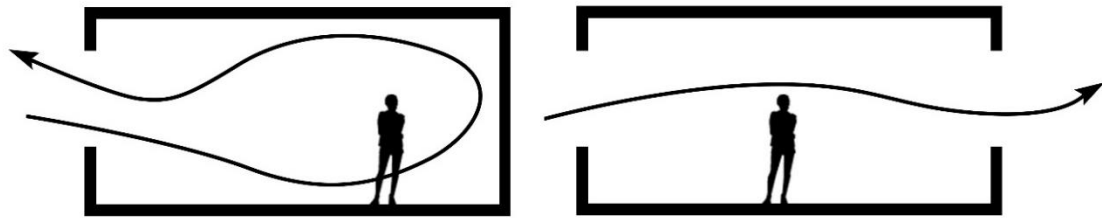

Figure 1. Single-sided ventilation (left) and cross-ventilation (right)

Stack Ventilation

If the speed of an air flow increases relative to the speed of the airflow next to it, the pressure of this air flow decreases. Airplane wings take off with this principle. This is called the Bernoulli effect. When a layered airflow is compressed to pass through an opening, its speed increases and its pressure decreases. This situation is called the Venturi effect (Darçın, 2008). The chimney effect occurs with convection techniques that use the Bernoulli principle and the Venturi effect together. Air moves within the building under the influence of pressure differences. Hot air rises and leaves the building through openings at the upper elevations (Figure 2).

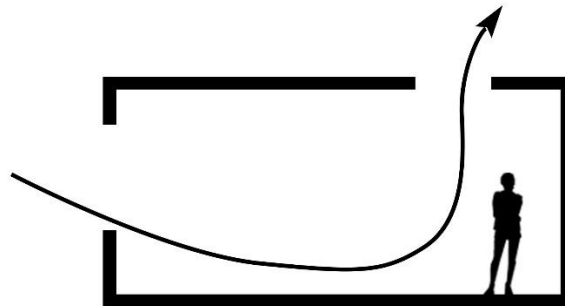

Figure 2. Stack ventilation

To reduce the pressure of the building in the prevailing wind direction, more cool air should be taken in through openings close to the ground. Solar chimneys can be arranged within the building to use the stack effect. The solar chimney, which is designed in a position that can receive sunlight, heats up during the day, allowing the air in the building to naturally direct in that direction, and the heated air leaves the building through the chimney. In the cold months, the solar chimney is closed to ensure that the warm air remains within the building. In this method, ventilation is provided by creating air movement only with temperature differences, without an effective prevailing wind.

Night Ventilation

In all climate types, night air temperatures are lower than daytime air temperatures. The air temperatures that decrease at night can be stored for the next day and used as a cooler. This type of cooling is called cooling through night ventilation.

The night ventilation method works most efficiently in hot and dry climates where temperature differences between day and night are above 17 °C. In these climates, daytime temperatures reach 38 °C and can drop to 21 °C at night. Positive results can also be achieved in some humid climates where the temperature difference between day and night is around 11 °C. Temperature differences between day and night are greater in continental regions than in maritime regions. For this reason, more efficient results can be obtained in continental regions (Yüksek and Esin, 2011).

Night ventilation is carried out in two stages. First of all, the building is cooled all night long by opening the windows at night. The next day, windows are kept closed to prevent

hot air from entering the building (Figure 3). In this way, the cold air inside is protected and comfort conditions are provided.

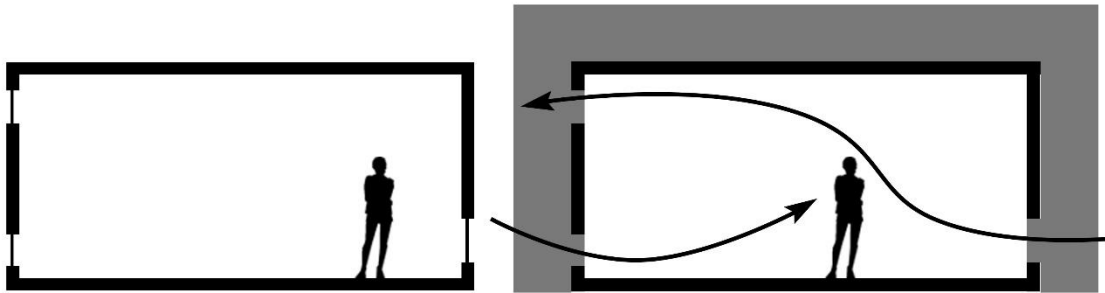

Figure 3. Night ventilation
Error! Bookmark not defined.

Double Skin Facades

In double-skin facade applications, the exterior of the building is designed as two layers. In order to benefit from sunlight and protect the facade from external climatic conditions, transparent components of the building are created with a gap between them. It is based on the fact that the space between the two layers serves as a ventilation channel (Yüceer, 2015). The second layer of glass allows solar radiation to heat the air in the space or corridor between the building envelope and the glass. The heated air rises and releases through the ventilation holes in the inner layer, similar to a solar chimney, and throws it out through the ventilation holes (Figure 4). The air gap between the double skin facade also functions as a corridor buffer area, with fresh air inlet and outlet facilitating natural ventilation. It is most preferred in temperate climates (Jaffe et al., 2020). One of the advantages of this facade type is that heat and sound insulation is strengthened thanks to the second layer on the facade.

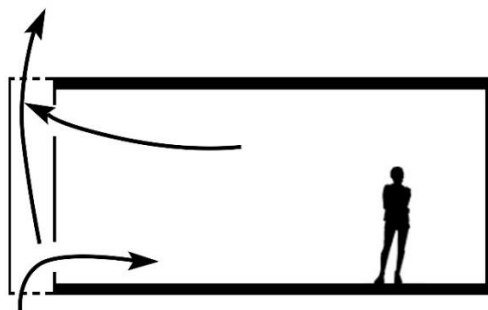

Figure 4. Double-skin facade ventilation

Cool Roof and Roof Venting

Cool roofs prevent buildings from overheating by reflecting sunlight and heat with the properties and color of the roof material. In this type of roof, the top layer is covered with a special reflective layer. Thus, heat entry into the building is minimized.

Additionally, the space left between the roof structure and the top floor ceiling slab provides ventilation and cooling in this section (Figure 5). Especially in climates where cooling loads are greater than heating loads, cool roof applications can make a big difference. It can even reduce overheating and the heat island effect in the city.

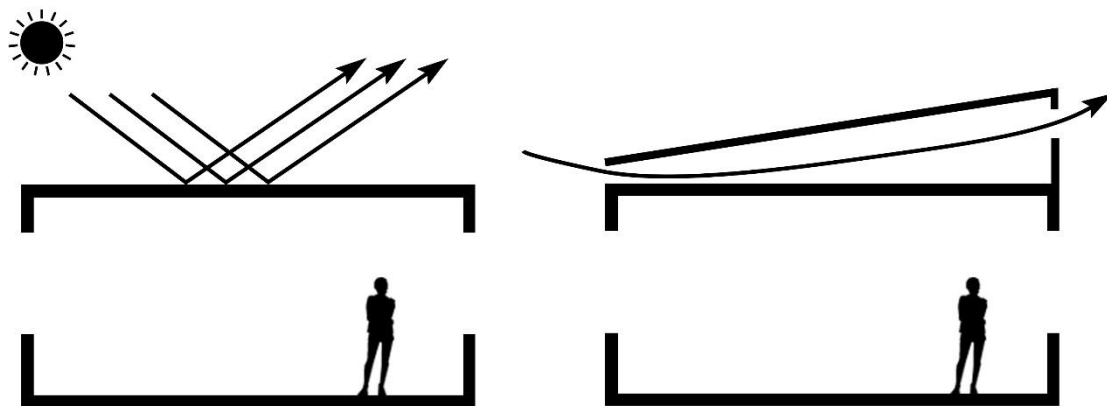

Figure 5. Cool roof and roof venting strategies

Green Roofs

Terms such as vegetated roof, green roof, living roof, eco-roof, and roof garden refer to a building roof that is fully or partially covered with vegetation and growing medium. In addition to serving as a fully functional roof, it can be a sloped roof surface or a flat surface designed to nourish vegetation (Abass et al. 2020).

Green roofs affect the thermal performance and cooling effect of the thermal insulation of the roof. Thermal insulation of green roofs, which mainly depends on the thickness of the growing medium, is one of the most important parameters that significantly affects the cooling effect (Figure 6). Research has shown that the surface temperatures of green roofs without insulation materials are cooler than traditional roofs (Jamei et al., 2021). The main reason for this is that the green roof prevents overheating by absorbing solar radiation. Soil and plants that release moisture into the air due to the effect of heat provide cooling with this heat transfer, and this is referred to as "evapotranspiration" in the literature. The spread of green roofs also helps reduce the urban heat island effect.

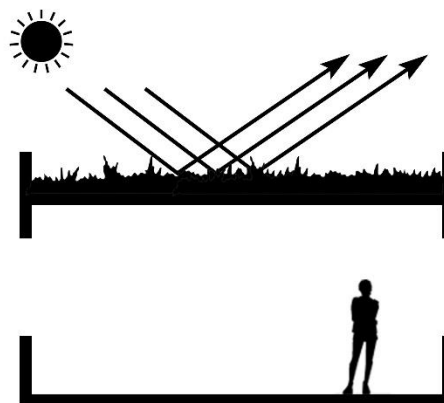

Figure 6. Preventing the roof from overheating with green roof

Cooling via Evaporation

Evaporative cooling can be used to cool buildings in dry, hot climates. When water evaporates, it removes heat and creates a cooling effect. Containing water, such as fountains in courtyards or a pond in a building, as the water evaporates it will have a cooling effect on the surrounding air (Figure 7). Evaporative cooling is most effective in hot, dry climates where adding moisture is beneficial and dry air facilitates efficient evaporation.

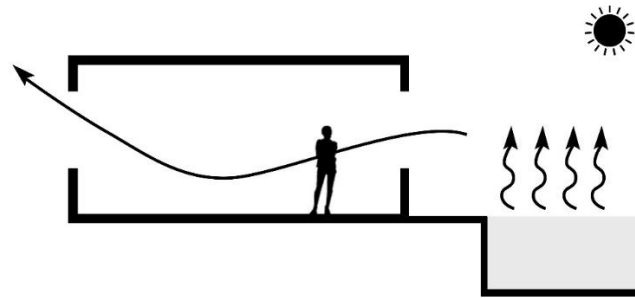

Figure 7. Cooling via evaporation

Shading Elements

Shading elements are elements used on transparent surfaces to minimize glare and excess solar heat that impair visual comfort (Figure 8). Window shading elements can be used as horizontal or vertical. Horizontal shades protect the building from excessive heat in the summer months when the sun rays are steeper while allowing the sun rays coming from more shallow angles to enter inside the building in the winter. This type of horizontal sunshade is mostly used in the south direction. Vertical sunshades are preferred to minimize the sun rays coming from the west direction. Buildings are heated during the day and sun rays from the west direction cause overheating of the interior. Vertical sunshades can be adjusted according to sunlight manually or by remote control. In this way, excessive solar flares are broken by vertical shading elements throughout the day and overheating is prevented.



Figure 8. Cooling via shading elements

Windcatchers

Windcatchers are ventilation towers that take clean air indoors and exhaust dirty air. Generally, in areas where the airflow is slow and the faster air flows are at upper elevations, it allows the fast airflow at the upper elevations to be taken into the building and the building is cooled by natural forces. They are also known as wind chimneys, wind towers, badgirs, and malkafs (Figure 9).

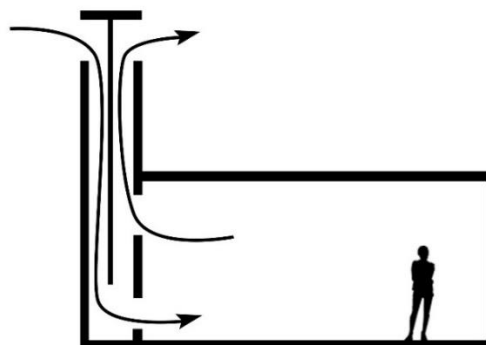

Figure 9. A typical windcatcher section



For air circulation to occur, pressure differences or temperature changes caused by wind force are necessary. Air enters the system through an opening where the pressure is positive. Wind creates a high-pressure area at the entrance point of the tower. If the wind tower is one-way, the air taken in is directed out through another opening in the building. If the wind tower is bidirectional, the dirty air is thrown out through the opening where negative pressure occurs (Rabeharivelo et al. 2022).

2.2. Computational Fluid Dynamics and Building Simulation

Computational fluid dynamics (CFD) are modern methods that enable the equations governing flow to be analyzed by converting them into numerical algorithms and using powerful computers. In some cases, in addition to flow problems, events such as heat transfer and chemical reactions may also occur. In these cases, in addition to the flow equations, the equations related to these events are also solved together. General equations representing flow problems are called Navier-Stokes equations. These equations most generally consist of the continuity equation, momentum equation, and energy equation. CFD software solves these equations, which have no analytical solutions except for a small number of simple flow states, numerically, with several decompositions and assumptions (Özcan, 2004).

Computational fluid dynamics simulations are widely used in building software to simulate the interactions of liquids and gases with solid surfaces. Airflow, liquid flow, heat flow, heat transfer, radiation, solar radiation, humidity, condensation, etc. CFD simulations are used to simulate many building physics phenomena. Since CFD is needed to calculate HVAC phenomena, building energy software is also CFD-based. CFD software that can perform air flow calculations can also be used to make simulations of the effect of wind currents around the building on the building. Software that simulates air flow to evaluate natural ventilation within the building can generally be used for this purpose (Orhon and Altın, 2017).

Today, CFD has gained a place as a design tool in the industry. It is seen that CFD is used in a wide range of industries such as automotive, heating, ventilation, maritime, construction, and chemistry. The industry generally uses it as a complementary engineering tool for experimental and theoretical fluid dynamics studies (Young, 2018). CFD started to be used in the field of architecture in the 1990s, and the number of CFD-based studies has been increasing since 1997 (Zhai, 2006). With CFD analysis, many physical phenomena can be simulated, such as heat transfer scenarios of buildings, natural and mechanical ventilation and flow simulations, and simulation of heat or airflow in urban spaces. In this respect, it is a convenient tool for architects to use both at urban and single-building scales.

CFD can be used for advanced design changes and energy efficiency solutions in the architectural field. This method optimizes the analysis of existing architectural systems and enables the reduction of energy consumption and the testing of sustainable design modules. One of the architectural applications of CFD is natural ventilation design. It helps designers realize optimum design by analyzing airflow efficiency, temperature distributions, and thermal conditions inside the building.

Architectural use of CFD can also be used to decrease the amount of energy to optimize heat transfer. Analysis of insulation materials and facade designs can help maintain the desired temperature conditions within the building. This can be considered as a way to focus on energy efficiency, a fundamental element of sustainable building design. The ability of CFD to capture solar radiation and winds has the potential to guide designers in optimizing building data. Thus, it may be possible to better adapt the building to existing climate conditions and obtain maximum benefit from natural energy resources. As a result, CFD has become an important tool in architecture, helping architects create more sustainable and effective building designs.

2.3. Method of the Study

For the study, a prototype mosque was designed initially by taking into consideration current practices and regulations in Türkiye and international literature. The wall, floor, and roof details of the building were drawn, and the U values of these surfaces were calculated according to TS825. TS825 is the Turkish standard on thermal insulation rules in buildings. It has been prepared for the calculation rules of net heating energy needs in buildings and the determination of the highest acceptable heating energy values in buildings. U value is the amount of heat passing per unit of time through 1 m² of the building element consisting of different material layers. Thermal insulation applications aim to reduce the U value as much as possible. The lower the U value, the less heat loss the building has. Five-year climate data (2018 - 2022) for July, which represents the hottest time of the year in Konya province, was obtained. The model loaded into the CFD software was shaped and analyzed in line with these data. Finally, the analysis results were interpreted comparatively.

The size of the mosque was determined after a meeting with the Presidency of Religious Affairs. The Presidency of Religious Affairs stated that the most commonly used mosque type is the mosque with a capacity of 500 people. For the study, a mosque with a central square plan, which is the most commonly used plan type in Turkey, and a capacity of 500 people, was designed. According to the "Mosque Planning and Design Guide" of the Presidency of Religious Affairs, 0.5 m² of space per person should be allocated when designing mosques. For this reason, a 250 m² worship area was designed for the prototype building that can be used by 500 people. Effective ventilation is provided when the window opening ratios are around 20% of the floor square meter (Jaffe et al., 2020). Accordingly, the opening ratio in the prototype mosque was designed as 22%. Konya represents a temperate dry climate. Thus, window to wall ratio, which expresses the ratio of transparent surfaces to solid surfaces, was determined as 35% for the north, east, and west directions for this study, according to the value determined for the temperate dry climate in Goia's (2016) study.

For Türkiye, the southeast direction is the qibla direction of mosques. Qibla is the direction that one faces during *namaz* prayer, which is a form of worship in Islam. This direction refers to turning towards the Kaaba building which is a sacred building for Muslims in the city of Mecca in Saudi Arabia. During worship, worship is performed by facing this direction (qibla), and since there should be no distracting elements in this direction, no openings are arranged in this direction in the prototype mosque. The prevailing wind will enter from the entrance façade on the northwest side of the mosque, and the air inlets are designed as three doors and three windows on the entrance facade. On the facades other than the qibla facade, the windows at ground level and the roof openings, which are the focus of the study, are designed as air outlet elements. The mosque building height was designed in accordance with the rates determined by the General Directorate of Foundations of Türkiye in the study compiled by Gürsoy (2018). In this context, it was designed to have an internal height of 15 meters (Figure 10).

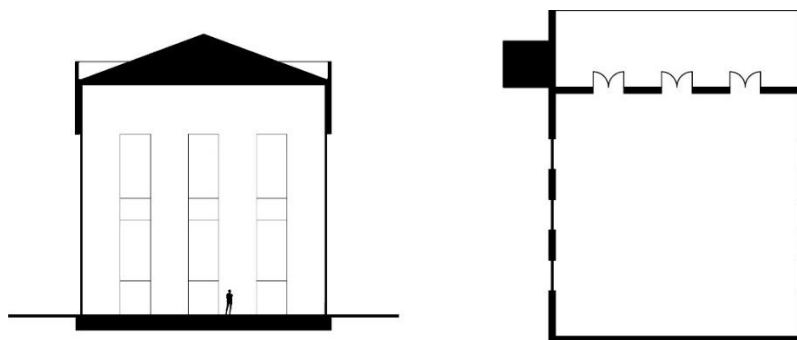

Figure 10. Section and plan of the prototype mosque



The thermal insulation details of the mosques were drawn to obtain the U values of the model surfaces. U values were calculated by entering the details into the IZODER TS825 program. U values are determined as 0.275 W/m²K for walls, 0.255 W/m²K for ceilings, 0.363 W/m²K for floors, and 1.80 W/m²K for windows. These values are in accordance with the ranges specified for Konya in TS825:2013, the standard that determines Türkiye's thermal insulation rules.

Since natural ventilation and cooling in mosques will be examined, the analysis was made according to the hottest month of the year. Temperature and wind data for five years (2018-2022) from July, which represents the hottest month of the year for Türkiye, were obtained from the General Directorate of Meteorology. The five-year average daytime temperature in July is 25.7 °C. The 5-year average wind speed in July is 3.8 m/s and the dominant wind direction is northwest.

All simulation study processes were carried out in ANSYS Fluent 2022. The simulation solution was realized using the geometry, mesh, setup, solution, and results in modules in the ANSYS program.

The prototype was first modeled in accordance with the measurements in Sketchup software and then transferred to ANSYS SpaceClaim. In the SpaceClaim module, the building geometry was arranged and the flow geometries in which the flow would take place were determined and made ready to create a solution network.

The solution network (mesh structure) was created in the ANSYS mesh module. The total number of elements of the model transferred to the solution is approximately 2.5 million. The models are created from rectangular cells only. The network structure of the model was created with a minimum element size of 20 cm for all edges, surfaces, and volumes. Conservation, energy equations, initial and boundary conditions, and loadings were determined in the Fluent module.

The "Shear stress transport (SST) k - ω model" was used as the turbulence model because it provides better results and convergence in viscous regions. "Solar ray tracing" model was used in the model for solar radiation, which helps to see the effects of both direct sunlight and diffused solar radiation.

For the study, the coordinates of Konya province were entered into the "Solar ray tracing" model, and the direction and intensity of solar rays were determined for the specified date and time. The simulation was carried out in the software for 14:00 on a day in July. This time was chosen to ensure that the use of the mosque is more intense in the afternoon and to better see the heat effect coming from the south side during this period.

For this study, the results were obtained as colored maps in the form of contour diagrams. In order to make the comparison more accurate and easier, the same temperatures and the same speeds are represented with the same colors.

3. RESULTS

Flow rates and indoor temperatures were measured with the help of software. Velocity contour maps and temperature contour maps were obtained. For an accurate comparison of scenarios, the color range of the maps has been arranged to represent the same temperatures with the same colors and the same speeds with the same colors. Since the measurement height is determined as 1.10 m in the ASHRAE-55 standard, temperatures and flow rates were taken at a height of 1.10 meters (Al-Homoud et al., 2009; Çalış et al., 2017). ASHRAE (American Society of Heating Refrigerating and Air Conditioning Engineers), is an international association working in the fields of building installation systems, energy efficiency, indoor air quality, and sustainability. ASHRAE Standard 55 specifies standard conditions for comfortable thermal environments and is intended for use

in the design, operation, and commissioning of buildings. ASHRAE Standard 55 is a respected standard accepted in the international literature on thermal comfort.

The building was heated with a solar model in ANSYS Fluent software, and the cooling capacity of the space was examined by taking the prevailing wind into the interior at the appropriate direction and temperature. The prevailing wind, taken from the entrance facade of the space, leaves the building through windows at ground level and the roof openings designed for the study. Figure 11 shows the external temperatures of the building at the specified time. As can be seen from the color scale, the roof is the part that receives the most heat. It can be said that there is a thermal low-pressure area in this warming region. Thus, the prevailing wind in the structure flows from the high-pressure region to this low-pressure region.

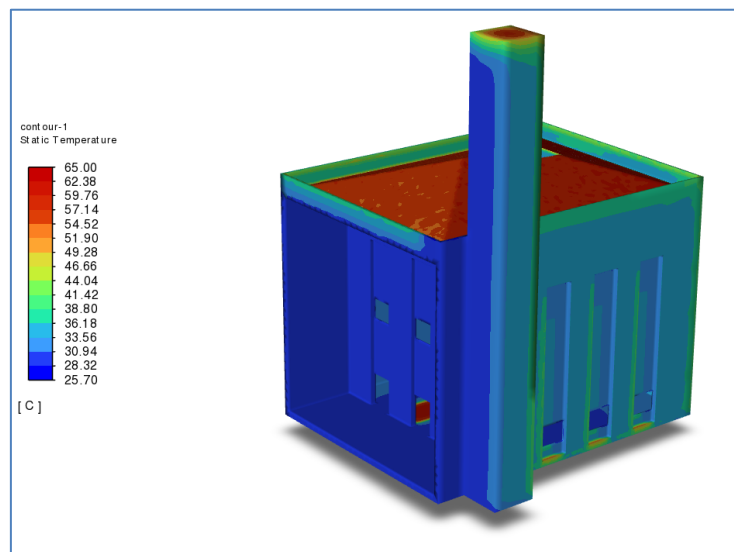

Figure 11. Temperature map showing external temperatures of the building

3.1. Flow Velocities

The prevailing wind accelerates from the entrance of the building and is taken into the building. Here, the flow accelerates as the flow narrows at the entry points into the building. The flow slows down a little inside the building, creating a turbulent flow inside the mihrab wall. The flows finally leave the building through ground-level windows on the side facades and different openings on the roof (Figure 12).

The airflow in the interior was obtained with contour maps with the help of software. These color maps reveal, through colors, the speed at which the airflow inside the space occurs. Here, a color scale starting from cool colors and moving towards warm colors can be seen. While cool colors represent areas where the flow rate is slowest, warm colors represent areas where the flow rate is fastest. A total of 12 colors were used for simulation. Colors vary between regions where the flow speed is close to zero (dark blue) and regions where the flow speed is close to 5m/s (red). Smooth transitions between colors in the resulting simulation graphics show that the solution network has been established correctly. In order to best visualize the air movement speeds within the building, a graphic was created by taking two vertical and horizontal sections. While the vertical section passes through the center of the building, the horizontal section is taken from the height that is important for the user, 1.10 meters. This height is the value specified for measurement height in the ASHRAE-55 standard.

When looking at the vertical contour map in Alternative 1 (A1), it is seen that the flow rates are slower than in Alternative 2 (A2). The blue and dark blue region representing the slowest flow rates is larger in A1. Since there is more than one air outlet opening in A2 on

the roof, flows accelerate in a larger area and leave the building, while a partial acceleration is observed in a smaller area in A1.

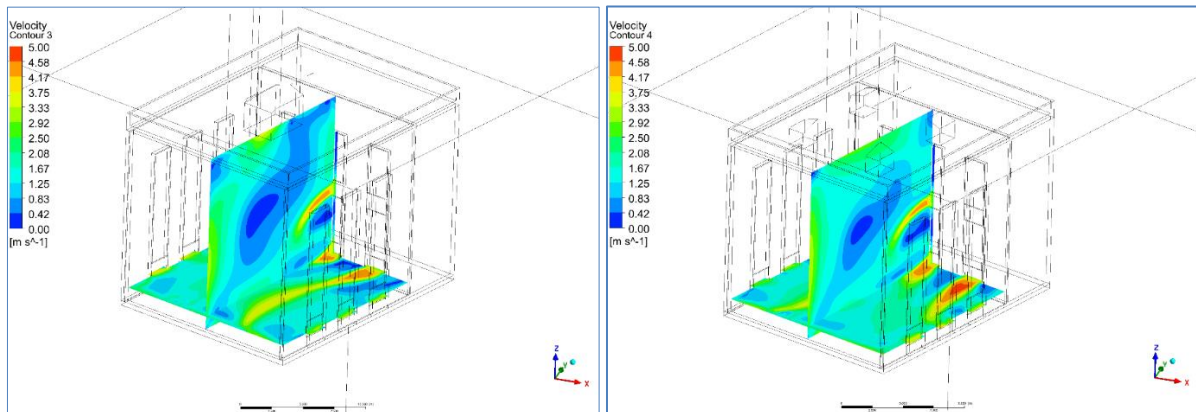

Figure 12. Velocity contour maps A1 (left) and A2 (right)

Streamline graphics allow the path of airflow within the structure to be seen in detail. With linear vectors, regions where the airflow moves linearly, regions where it changes direction, or regions where turbulent flow occurs can be easily observed. The colors of the linear expressions show the flow speed as well.

Figure 13 shows the streamlined graphics of A1 and A2. In the A1 scenario, the airflow basically moves linearly at the point where it is taken into the building, and after hitting the mihrab wall, it is directed upwards. In this way, it moves along the ceiling and changes direction at the wall it hits again and moves downwards. This flow, which changes direction and travels throughout the building, represents the turbulent flow type and shows a more regular movement than A2. When the graphs are examined, it is seen that there is a more complex and turbulent flow in A2 compared to A1. Ventilation is provided more effectively in the A2 scenario, which represents a more complex turbulent flow in different directions within the building. This is an indication that more cooling is provided.

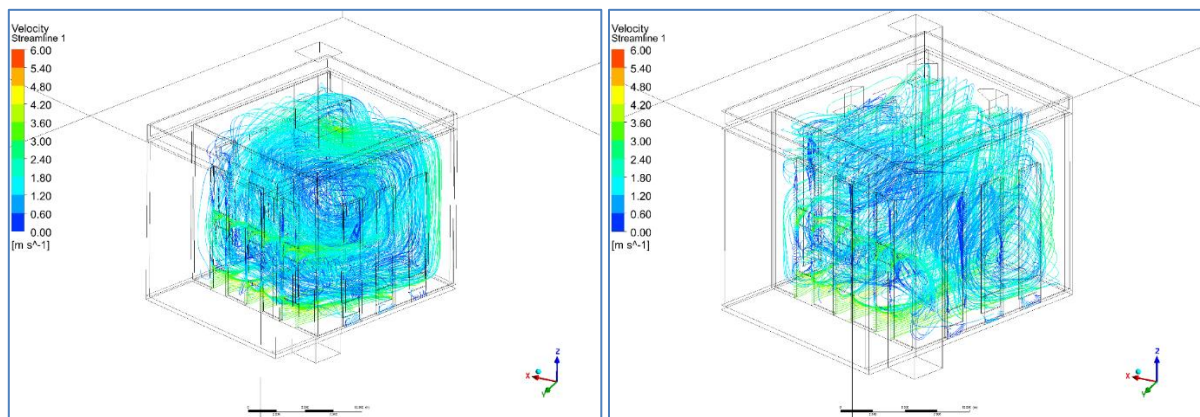

Figure 13. Streamline graphics of A1 (left) and A2 (right)

3.2. Indoor Temperatures

Temperature contour maps were used to visualize the simulation of indoor temperatures. These color maps show how temperatures inside the space vary by region. Here, a color scale starting from cool colors and moving towards warm colors can be seen. Cool colors represent low temperatures, and warm colors represent high temperatures. The color range represents the range between 25.7 °C and 32 °C. Smooth transitions between colors in the resulting simulation graphics show that the solution network has been established accurately.

Figure 14 shows the indoor temperature contour diagrams of A1 and A2. According to the temperature diagram of A1, 23.99% of the space is at 27.80 - 28.33 °C, and 48.47% of the space is at 27.27 - 27.80 °C. 20.70% of the space is at 26.75 - 27.27 °C. Other parts represent under 10% of the space. According to the diagram of A2, 15.51% of the space is at 27.80-28.33 °C, and 39.96% of the space is at 27.27 - 27.80 °C. 32.00% of the space is at 26.75 - 27.27 °C, 10.69% of the space is at 26.23 - 26.75 °C. Other parts represent under 10% of the space.

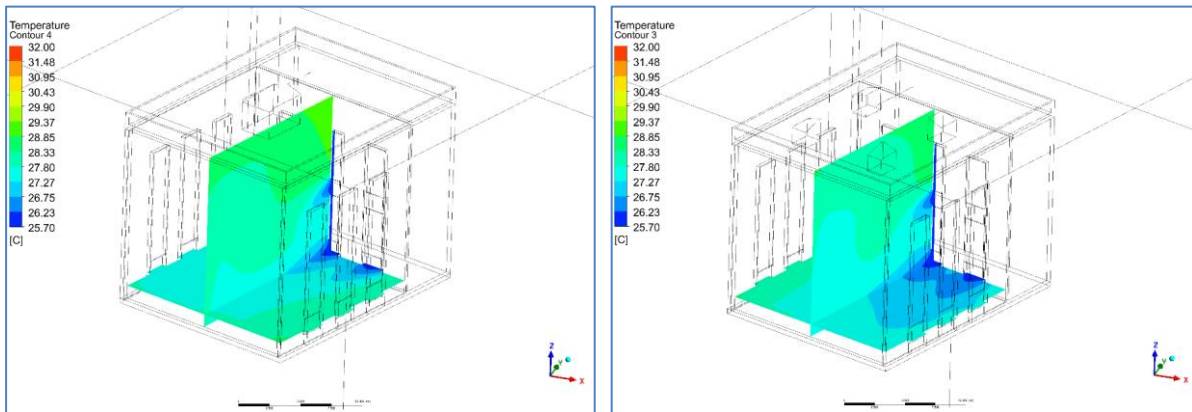

Figure 14. Indoor temperature contour maps of A1 (left) and A2 (right)

Figure 15 shows horizontal graphs of indoor temperatures analyzed based on a height of 1.10 meters. To make comparison easier, temperatures on the plan plane are shown side by side in a single image. Based on the temperature range of 26.23 - 27.80 °C, 82.65% of A1 is in this range, while 74.80% of A2 is in this range. While 15.51% of A2 is in the range of 27.8 - 28.33 °C, 23.99% of A1 is in this range. When the results are compared, it is seen that Alternative 2 is more successful in terms of cooling. This revealed that while the outlet size remained constant, increasing the number of openings had a positive effect on providing passive cooling.

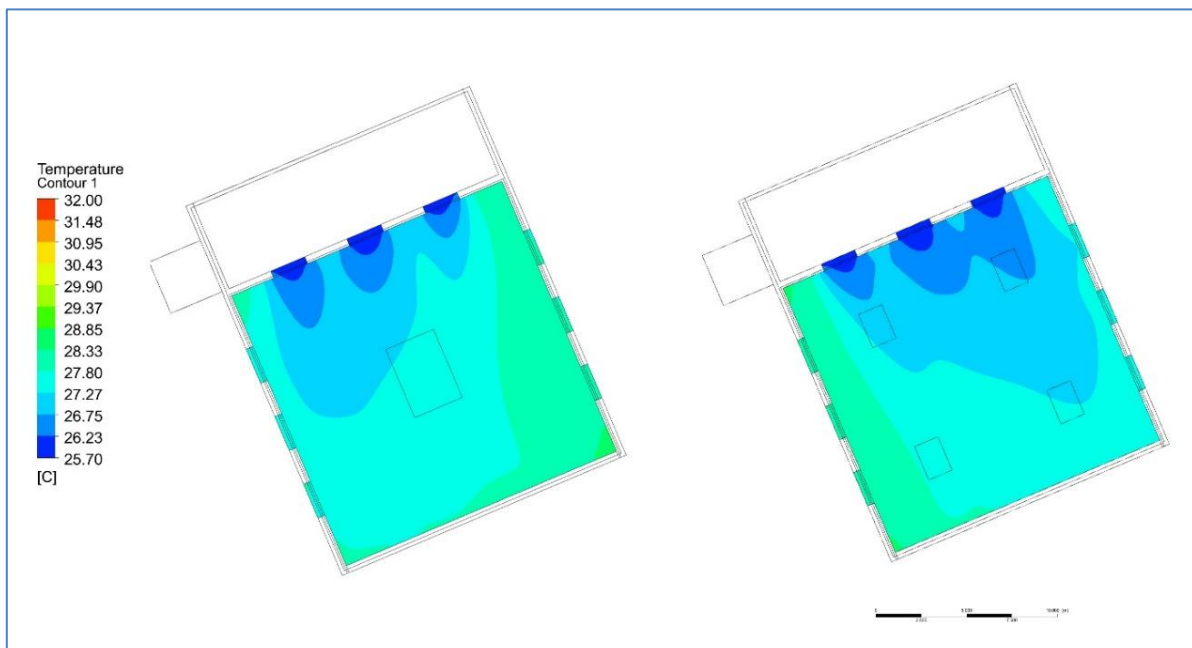

Figure 15. Indoor temperature contour maps of A1 and A2 at a height of 1.10 meters

4. CONCLUSION

In our country, discussions on mosque architecture are stuck between the stylized use of traditional forms and disproportionate imitations of 16th century Ottoman Architecture.



There are a few modern mosques that get rid of this sense of nostalgia and focus on the function of worship. However, the function of worship requires certain comfort conditions, like other activities during the day (Azkur, 2021). Providing this comfort correctly will also make worshipping easier. In this context, the physical conditions of mosques must be also the subject of academic research. The energy spent to provide these comfort conditions is also very important in terms of sustainability. For our goal of reducing carbon emissions, cooling energy consumption in mosques must be reduced. Passive cooling is also a sustainable method that should be considered as a natural alternative to this energy consumption. Today, modern mosques, which are generally designed with fixed windows, ignore the contribution that roof openings can make to natural ventilation. In this study, the passive cooling effect of natural ventilation and roof openings is demonstrated through a case study. As a result of the study, it was seen that designing roof openings in the mosque design had a positive effect on passive cooling of the building. It has been observed that when more than one opening is preferred instead of a single opening in the design, better air circulation is achieved and cooling is more successful, although the total opening size remains constant. As the number of roof openings increased, a more complex and turbulent flow occurred. This increased the cooling capacity of the cooling airflow. In this context, a criterion has been introduced for architects to use in the early design phase. When designing a mosque, architects can consider designing roof openings, and while doing this design, they can increase the cooling effect of the openings by distributing more than one roof opening in a balanced manner throughout the space.

In future studies, other passive cooling strategies can be applied and simulated in mosque buildings. New criteria can be introduced for effective passive cooling in the context of mosques.

ACKNOWLEDGEMENT

The corresponding author of the study, Hatice Sena Azkur, is supported as a YÖK 100/2000 PhD program scholar.

REFERENCES

- Abass, F., Ismail, L. H., Wahab, I. A., & Elgadi, A. A. (2020). A review of green roof: definition, history, evolution and functions. In IOP Conference Series: Materials Science and Engineering (Vol. 713, No. 1, p. 012048). IOP Publishing.
- Alhasan, W., & Yuning, C. (2019). Environmental analysis of Nanjing Mosque courtyard layout based on CFD simulation technology. In *E3S Web of Conferences* (Vol. 136, p. 04040). EDP Sciences.
- Al-Homoud, M. S., Abdou, A. A., & Budaiwi, I. M. (2009). Assessment of monitored energy use and thermal comfort conditions in mosques in hot-humid climates. *Energy and Buildings*, 41(6), 607-614.
- Al Sudany, J.A.A.W. (2015). Employment Minarets Wind-catcher Natural Ventilation and Passive Cooling in the Mosques of Baghdad. *International Journal of Current Engineering and Technology*, 5(5), 3186-3192.
- Asfour, O. S. (2009). Effect of mosque architectural style on its thermal performance. *The Islamic University Journal (Series of Natural Studies and Engineering)*, 17(2), 61-74.
- Atmaca, A. B., & Gedik, G. Z. (2019). Evaluation of mosques in terms of thermal comfort and energy consumption in a temperate-humid climate. *Energy and Buildings*, 195, 195-204.
- Azkur H.S. (2021). Camilerde harim ve avlu mekanlarının biçimlenişinin kullanıcı hareketine etkisinin mekansal dizim yöntemi ile değerlendirilmesi. In B. Yılmaz Çakmak, (Ed.), *İnsan hareketlerinin değişiminin mekan biçimi üzerindeki etkisinin yorumlanmasında mekana dizimsel bakış* (pp.155-166) Nobel Yayıncılık.
- Azmi, N. A., Arıcı, M., & Baharun, A. (2021). A review on the factors influencing energy efficiency of mosque buildings. *Journal of Cleaner Production*, 292, 126010.



- Budaiwi, I.M., Abdou, A.A., & Al-Homoud, M.S. (2013). Envelope retrofit and air-conditioning operational strategies for reduced energy consumption in mosques in hot climates. *Building Simulation*, 6:33-50.
- Çalış, G., Kuru, M., & Alt, B. (2017). Bir eğitim binasında ısı konfor koşullarının analizi: İzmir’de bir alan çalışması. *Uludağ Üniversitesi Mühendislik Fakültesi Dergisi*, 22(2), 93-106.
- Darçın, P. (2008). Yapı içi hava kirliliğinin giderilmesinde doğal havalandırma ilkeleri [Unpublished doctoral dissertation]. Yıldız Technical University.
- Diler, Y., Turhan, C., Arsan, Z. D., & Akkurt, G. G. (2021). Thermal comfort analysis of historical mosques. Case study: The Ulu Mosque, Manisa, Turkey. *Energy and Buildings*, 252, 111441.
- Goia, F. (2016). Search for the optimal window-to-wall ratio in office buildings in different European climates and the implications on total energy saving potential, *Solar Energy*, 132, 467-492.
- Gürsoy, E. (2018). Cami tip projelerinde ölçü-oran ilişkisi. *Türk Dünyası Araştırmaları*, 118(232), 211-228.
- Imam, S.N. (2003). Ventilation in a mosque—an additional purpose the minarets may serve. Paper presented at the 7th International Conference Healthy Buildings, Singapore.
- Jaffe, S. B., Fleming, R., Karlen, M., & Roberts, S. H. (2020). *Sustainable design basics*. John Wiley & Sons.
- Jamei, E., Chau, H. W., Seyedmahmoudian, M., & Stojcevski, A. (2021). Review on the cooling potential of green roofs in different climates. *Science of the Total Environment*, 791, 148407.
- Maarof, S. (2014). *Roof designs and affecting thermal comfort factors in a typical naturally ventilated Malaysian mosque*. [Unpublished Doctoral dissertation]. Cardiff University.
- Mohammed, A. G., AbdelGawad, A. F., & Nassief, M. M. (2020). Artificial Neural Networks to Assess the Effect of Window Parameters on Indoor Natural Ventilation in “Sultan Al-Ashraf Qaytbay” Mosque. *The Egyptian International Journal of Engineering Sciences and Technology*, 30, 51-65.
- Mushtaha, E., & Helmy, O. (2017). Impact of building forms on thermal performance and thermal comfort conditions in religious buildings in hot climates: a case study in Sharjah city. *International Journal of Sustainable Energy*, 36(10), 926-944.
- Nordin, N. I., & Misni, A. (2017). A comparative study on the indoor thermal performance of new and old mosques. *Environment-Behaviour Proceedings Journal*, 2(5), 23.
- Nordin, N. I., & Misni, A. (2018). Evaluating the interior thermal performance of mosques in the tropical environment. In *IOP Conference Series: Earth and Environmental Science* (Vol. 117, No. 1, p. 012014). IOP Publishing.
- Orhon, A. V., & Altın, M. (2017). Mimari sürdürülebilirlik için bir değerlendirme aracı olarak benzetim. *Tesisat Mühendisliği*, 158, 5-13.
- Othman, F. Z., Ahmad, S. S., & Hanapi, N. L. (2019). The relationship between ventilation and opening strategies of domed mosque for indoor comfort. *e-Academia Journal*, vol. Special Issue, 85-91.
- Özcan, O. A. (2004). Uçak kanatlarının CFD analizi [Unpublished master’s thesis]. Istanbul Technical University.
- Rabeharivelo, R., Kavraz, M., & Aygün, C. (2022). Thermal comfort in classrooms considering a traditional wind tower in Trabzon through simulation. In *Building Simulation*, 15(3), 401-418.
- Rahim, M., & Marasabessy, F. (2019, April). Evaluation of natural ventilation characteristics on the Sultanate of Ternate Mosque. In *IOP Conference Series: Materials Science and Engineering* (Vol. 506, No. 1, p. 012035). IOP Publishing.
- Raslı, N. B. I., Ramli, N. A., Ismail, M. R., Zainordin, N. S., & Razman, M. R. (2021). Effectiveness of Ventilation Strategies in Reducing the Temperature in the Main Prayer Halls of Mosques in Malaysia. *Journal of Engineering Science and Technology*, 16(4), 2960-2979.



- Ray, S. D., Sadaba, S., & Leung, L. (2017). Intelligently controlled naturally ventilated mosque—a case study of applying design tools throughout the design process. *International Journal of Ventilation*, 16(2), 124-133.
- Sanusi, A. N. Z., Abdullah, F., Azmin, A. K., & Kassim, M. H. (2019). Passive design strategies of colonial mosques in Malaysia. In *Green Buildings and Renewable Energy: Med Green Forum 2019-Part of World Renewable Energy Congress and Network* (pp. 247-262). Springer International Publishing.
- Taleb, H. M. (2014). Using passive cooling strategies to improve thermal performance and reduce energy consumption of residential buildings in UAE buildings. *Frontiers of architectural research*, 3(2), 154-165.
- Young, D. F., Munson, B. R., Okiishi, T. H., Huebsch, W. W. (2018). *Akışkanlar mekaniğine giriş* (5th Ed). Nobel Academic Publishing.
- Yusoff, W. F. M., & Ja'afar, N. H. (2019). Preliminary evaluation of indoor thermal comfort in Malaysia heritage mosque. In *MATEC Web of Conferences* (Vol. 277, p. 02016). EDP Sciences.
- Yüceer, N. S., (2015). *Yapıda çevre ve enerji*. Nobel Academic Publishing.
- Yüksek, İ., & Esin, T. (2011). Yapılarda Enerji Etkinliği Bağlamında Doğal Havalandırma Yöntemlerinin Önemi. *Tesisat Mühendisliği*, 125, 63-77.
- Yüksel, A., Arıcı, M., Krajčák, M., & Karabay, H. (2020). Experimental investigation of thermal comfort and CO₂ concentration in mosques: A case study in warm temperate climate of Yalova, Turkey. *Sustainable Cities and Society*, 52, 101809.
- Yüksel, A., Arıcı, M., Krajčák, M., Civan, M., & Karabay, H. (2021). A review on thermal comfort, indoor air quality and energy consumption in temples. *Journal of Building Engineering*, 35, 102013.
- Zhai, Z. (2006). Application of computational fluid dynamics in building design: aspects and trends. *Indoor and Built Environment*, 15 (4), 305-313.